

Pipe joint assemblies and fittings for
high-density polyethylene (PE-HD) pressure pipes
Adaptors for fusion jointing, flanges and sealing elements
Dimensions

DIN
16 963
Part 4

Rohrverbindungen und Rohrleitungsteile für Druckrohrleitungen aus Polyethylen hoher Dichte (PE-HD);
Bunde für Heizelement-Stumpfschweißung, Flansche, Dichtungen; Maße

*In keeping with current practice in standards published by the International Organization for Standardization (ISO),
a comma has been used throughout as the decimal marker.*

Dimensions in mm

1 Field of application

This standard specifies dimensions of adaptors for fusion jointing using heated tools, of flanges and sealing elements used to interconnect high-density polyethylene (PE-HD) pressure pipes as specified in DIN 8074 and to connect such pipes to pipes and fittings made from materials other than PE-HD. The adaptors and flanged joints shall comply with the requirements specified in DIN 16 963 Part 5 (at present at the stage of draft). For technical reasons, adaptors shall only be welded to pipes conforming to DIN 8074 or to pipe components of the same pipe series, the use of other components being permitted if their wall thickness in the weld area is equal to that of the pipes.

2 Dimensions, designation

Adaptors, flanges and sealing elements are not expected to conform to the designs illustrated here; compliance is only required in the case of the dimensions specified. For dimensions without tolerance indication, the general tolerances given in DIN 7168 Part 1 or DIN 16 901 shall apply, at the manufacturer's discretion.

Continued on pages 2 to 8

No part of this standard may be reproduced without the prior permission of DIN Deutsches Institut für Normung e. V., Berlin.
In case of doubt, the German-language original should be consulted as the authoritative text.

Short adaptor
(item No.1)

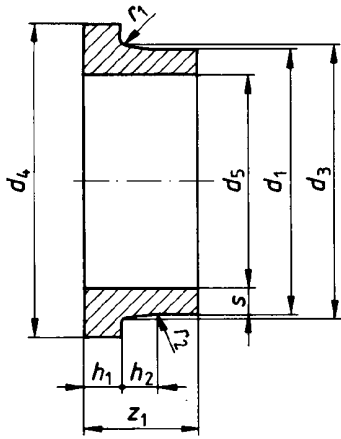

Short adaptor
(item No.23)

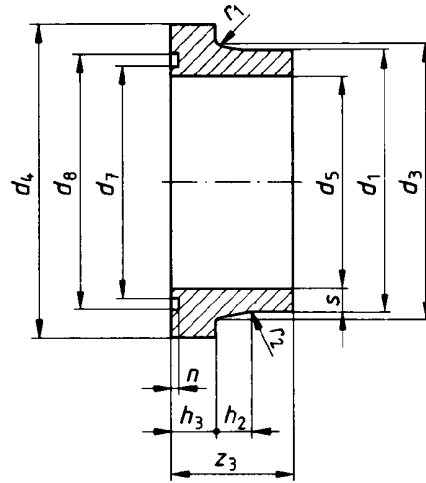

Long adaptor
(item No.3)

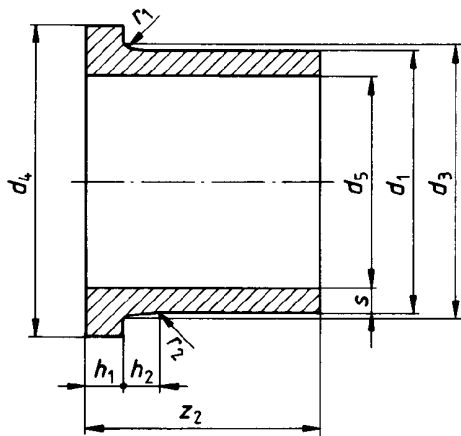

Long adaptor
(item No.24)

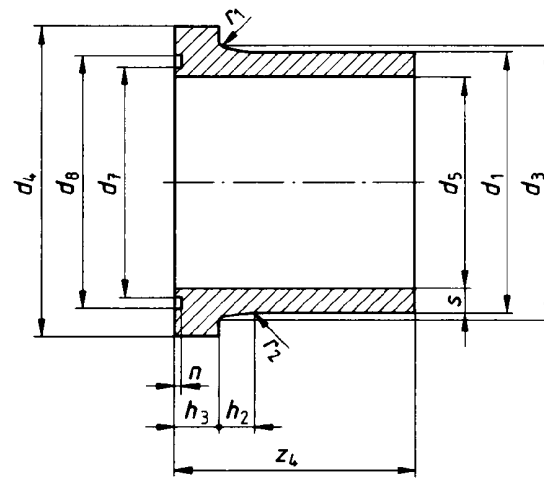

Example of a series 5 PE-HD adaptor (item No. 3) designed for a pipe outside diameter of 200 mm:
Adaptor DIN 16963 – 3 – 200 – 5 – PE-HD

Table 1. Adaptors (item Nos. 1, 3, 23 and 24)

Pipe out-side diameter, d_1	d_3	d_4	d_5 1)										d_7	d_8	n	h_1 Pipe series					h_2 Pipe series					r_1	r_2	z_1	z_2	z_3	z_4	
			2		3		4		5		PN 3,2	PN 4				PN 6	PN 10	Limit deviations	2	3	4	5	2	3	4							5
			Limit deviations	Limit deviations	Limit deviations	Limit deviations																										
20	27	45	-	-	16	+0,4	15	+1,2	20,9	29,7	-	-	7	13	-	-	10	-	-	-	10	12	12	13	13	50	85	53	88			
25	33	58	-	-	21	+0,4	19	+1,4	25,7	34,5	-	-	9	13	-	-	12	-	-	-	12	12	12	13	13	50	85	53	88			
32	40	68	-	-	27	+0,4	25	+1,2	33,6	42,4	-	-	10	13	-	-	13	-	-	-	13	13	13	13	13	50	85	53	88			
40	50	78	-	-	36	+0,4	31	+1,6	40,1	53,7	-	-	11	15	-	-	16	-	-	-	16	16	16	16	16	50	85	53	88			
50	61	88	46	+0,4	45	+0,4	39	+0,8	49,6	63,2	4,3	4,3	12	15	-	-	17	-	-	-	17	17	17	17	17	50	85	53	88			
63	75	102	58	+1	57	+0,8	50	+1,4	65,3	78,9	5,6	5,6	14	20	-	-	19	-	-	-	19	19	19	19	19	50	85	53	88			
75	89	122	69	+1,2	68	+1,2	59	+2,2	78,0	91,6	4,3	4,3	16	20	-	-	21	-	-	-	21	21	21	21	21	50	125	55	130			
90	105	138	83	+1,4	82	+1,4	71	+2,6	96,9	110,5	4,3	4,3	17	20	-	-	22	-	-	-	22	22	22	22	22	80	140	85	145			
110	125	158	102	+0	100	+0,4	88	+2	114,8	132,8	5,6	5,6	18	25	-	-	24	-	-	-	24	24	24	24	24	80	160	86	166			
125	132	158	116	+1,2	114	+1,2	99	+3,2	114,8	132,8	5,6	5,6	18	25	-	-	24	-	-	-	24	24	24	24	24	80	170	86	166			
140	155	188	130	+1,2	128	+1,2	111	+3,4	146,2	160,2	5,6	5,6	18	25	-	-	24	-	-	-	24	24	24	24	24	80	200	86	206			
160	175	212	149	+1	146	+1,6	127	+3,8	171,6	189,6	5,6	5,6	18	25	-	-	24	-	-	-	24	24	24	24	24	80	200	86	206			
180	180	212	167	+1,8	164	+2	143	+4,8	160,2	178,4	5,6	5,6	18	25	-	-	24	-	-	-	24	24	24	24	24	80	200	86	206			
200	232	268	186	+1,6	183	+3,2	159	+4,6	192	210,2	5,6	5,6	18	25	-	-	24	-	-	-	24	24	24	24	24	80	200	86	206			
225	235	268	209	+0	205	+0	179	+2,9	197,8	216	5,6	5,6	18	25	-	-	24	-	-	-	24	24	24	24	24	80	200	86	206			
250	285	320	232	+0	228	+0	199	+0	-	-	-	-	20	25	-	-	24	-	-	-	24	24	24	24	24	100	100	-	-			
280	291	320	260	+0	256	+0	223	+0	-	-	-	-	20	25	-	-	24	-	-	-	24	24	24	24	24	100	100	-	-			
315	335	370	293	+0	288	+0	251	+0	-	-	-	-	20	25	-	-	24	-	-	-	24	24	24	24	24	100	100	-	-			
355	373	430	330	+0	324	+0	283	+0	-	-	-	-	23	30	-	-	23	-	-	-	23	23	23	23	23	120	120	-	-			
400	427	482	372	+0,4	366	+0,4	319	+0,4	-	-	-	-	26	33	-	-	26	-	-	-	26	26	26	26	26	120	120	-	-			
450	514	585	419	+0	411	+0	359	+0	-	-	-	-	33	46	-	-	33	-	-	-	33	33	33	33	33	120	120	-	-			
500	530	585	465	+0	457	+0	399	+0	-	-	-	-	33	46	-	-	33	-	-	-	33	33	33	33	33	120	120	-	-			
560	615	685	521	+0	512	+0	447	+0	-	-	-	-	35	50	-	-	35	-	-	-	35	35	35	35	35	120	120	-	-			
630	642	685	586	+0,4	576	+0,4	503	+0,4	-	-	-	-	35	50	-	-	35	-	-	-	35	35	35	35	35	120	120	-	-			
710	737	800	661	+0	649	+0	621	+0	-	-	-	-	35	50	-	-	35	-	-	-	35	35	35	35	35	120	120	-	-			
800	840	905	745	+0	732	+0	700	+0	-	-	-	-	36	52	-	-	36	-	-	-	36	36	36	36	36	120	120	-	-			
900	944	1005	838	+0	823	+0	787	+0	-	-	-	-	40	55	-	-	40	-	-	-	40	40	40	40	40	120	120	-	-			
1000	1047	1110	931	+0	915	+0	875	+0	-	-	-	-	42	60	-	-	42	-	-	-	42	42	42	42	42	140	140	-	-			
1200	1245	1330	1117	+0	1098	+0	-	+0	-	-	-	-	50	60	-	-	50	-	-	-	50	50	50	50	50	140	140	-	-			

1) From $d_1 = 225$ mm, the specified values of d_5 allow for the tapering of the pipe.

2) For pipe series 5, $z_1 = 130$ mm.

Flange (item No.2)

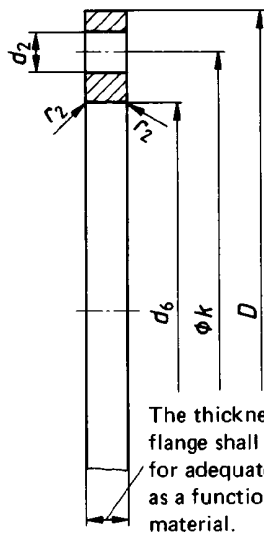

Designation of a glass fibre reinforced plastics⁵⁾ flange (item No.2) for a pipe outside diameter of 75 mm and rated for PN 10:

Flange DIN 16963 – 2 – 75 – 10 GFK

Table 2. Flanges (item No. 2)

Nominal flange size DN	Pipe outside diameter, d_1	$D^4)$	$d_2^4)$	$d_6^3)$	$k^4)$	Bolts		r_2
						Number	Thread size	
15 20 25	20 25 32	95 105 115	14	28 34 42	65 75 85	4	M12	3
32 40 50	40 50 63	140 150 165	18	51 62 78	100 110 125	4	M16	3
65 80 100	75 90 110	185 200 220	18	92 108 128	145 160 180	4 8 8	M16	3
100 125 150	125 140 160	220 250 285	18 18 22	135 158 178	180 210 240	8	M16 M16 M20	3
150 200 200	180 200 225	285 340 340	22	188 235 238	240 295 295	8	M20	3
250 250 300	250 280 315	395 395 445	22	288 294 338	350 350 400	12	M20	3
350 400 500	355 400 450	505 565 670	22 26 26	376 430 517	460 515 620	16 16 20	M20 M24 M24	4 4 6
500 600 600	500 560 630	670 780 780	26 30 30	533 618 645	620 725 725	20 20 24	M24 M27 M27	4 7 4
700 800 900 1000 1200	710 800 900 1000 1200	895 1015 1115 1230 1455	30 33 33 36 39	740 843 947 1050 1260	840 950 1050 1160 1380	24 24 28 28 32	M27 M30 M30 M33 M36	5 5 5 5 6

3) From $d_1 = 63$ mm, identical with the values given in DIN 2673, except for $d_1 = 450$ mm and 560 mm, where d_6 values are identical with those given in DIN 2642.

4) See DIN 2501 Part 1 for flange connecting dimensions.

5) See table 5 for flange materials and for material symbols to be used in the designation.

Gasket (item No.7) 6)

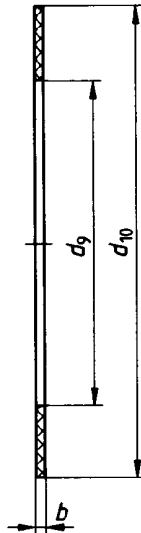

Designation of a pipe series 3 gasket (item No.7) designed for a pipe outside diameter of 250 mm:

Gasket DIN 16963-7-250-3

6) Other suitable cross-sectional dimensions shall be permitted.

Table 3. Gaskets (item No.7)

Pipe outside diameter, d_1	d_{10}	d_9 Pipe series				b
		2	3	4	5	
20	45	—	—	—	16	2
25	58	—	—	21	20	
32	68	—	—	28	26	
40	78	—	36	35	33	2
50	88	—	46	44	41	
63	102	59	58	56	51	
75	122	70	69	66	61	2
90	138	84	83	80	74	2
110	158	103	101	97	90	3
125	158	117	115	111	102	3
140	188	131	129	124	114	
160	212	150	148	142	131	
180	212	169	166	160	147	3
200	268	188	185	177	164	
225	268	211	208	199	184	
250	320	234	231	222	204	3
280	320	263	258	248	229	
315	370	295	291	279	258	
355	430	333	328	315	290	3
400	482	375	369	355	327	
450	585	422	415	399	368	
500	585	469	461	443	409	3
560	685	525	517	497	456	
630	685	591	581	559	513	
710	800	666	655	630	—	3
800	905	750	738	709	—	
900	1005	844	831	798	—	
1000	1110	938	923	885	—	
1200	1330	1126	1108	—	—	

O ring (item No.8)

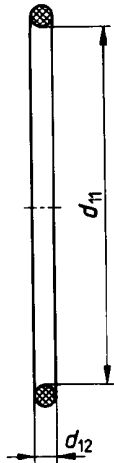

Table 4. O rings (item No.8)

Pipe outside diameter, d_1	d_{11}		d_{12}		Identical with (standard designation of O ring)
		Limit deviations		Limit deviations	
20 25 32	23,4 28,2 36,1	$\pm 0,4$	3,5	$\pm 0,1$	DIN 8063 - 16 - 20 DIN 8063 - 13 - 25 DIN 8063 - 16 - 32
40 50 63	43,8 53,3 69,2	$\pm 0,5$ $\pm 0,5$ $\pm 0,7$	5,3	$\pm 0,13$	DIN 8063 - 16 - 40 DIN 8063 - 16 - 50 DIN 8063 - 16 - 63
75 90 110	81,9 101 120	$\pm 0,7$	5,3 5,3 7	$\pm 0,13$ $\pm 0,13$ $\pm 0,15$	DIN 8063 - 16 - 75 DIN 8063 - 16 - 90 DIN 8063 - 16 - 110
125 140 160	120 151,8 177,2	$\pm 0,7$ $\pm 1,2$ $\pm 1,2$	7	$\pm 0,15$	DIN 8063 - 16 - 110 DIN 8063 - 16 - 140 DIN 8063 - 16 - 160
180 200 225	164,4 196,2 202,5	$\pm 1,2$	7	$\pm 0,15$	DIN 16963 - 8 - 180 DIN 16963 - 8 - 200 DIN 16963 - 8 - 225

3 Materials

Table 5. Materials

Name of component	Item No.	Permitted material							PE-HD
		GG	St	Al	PP-GF	PVC	GFK		
Short adaptor	1								X
Short adaptor	23								X
Long adaptor	3								X
Long adaptor	24								X
Flange	2	X	X	X	X	X	X		
Gasket	7	Materials subject to agreement.							
O ring	8								

The materials suitable for the components listed are marked X.

GG = cast iron (grey cast iron) as specified in DIN 1691

St = USt 37-2 or RSt 37-2 as specified in DIN 17 100, at the manufacturer's discretion

Al = light alloy

PP-GF = glass fibre reinforced polypropylene

PVC = PVC-U as specified in DIN 8063 Part 5

GFK = glass fibre reinforced plastics

PE-HD = high-density polyethylene as specified in DIN 16963 Part 5 (cf. Explanatory notes)

For item Nos. 7 and 8, the material shall be agreed as a function of the type, concentration and service temperature of the medium conveyed.

4 Assemblies

Adaptors, flanges and sealing elements as specified in clause 2 may be used to make the flanged joints shown below.

Type F1 flanged joint (for sizes from DN 15 to DN 1200) **Type F6 flanged joint** (for sizes from DN 15 to DN 200)

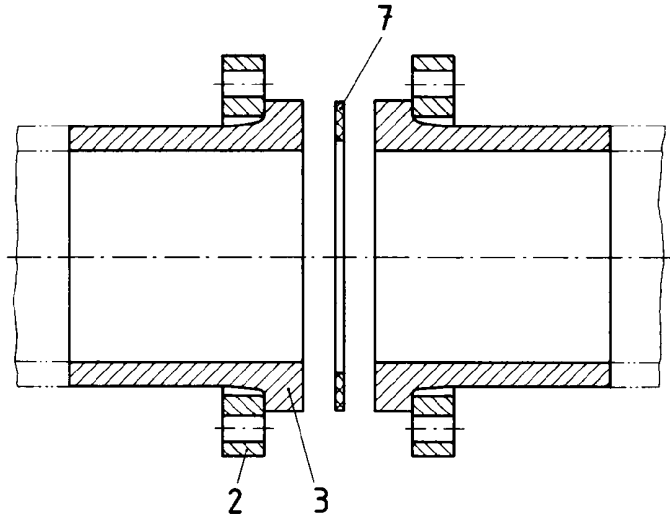
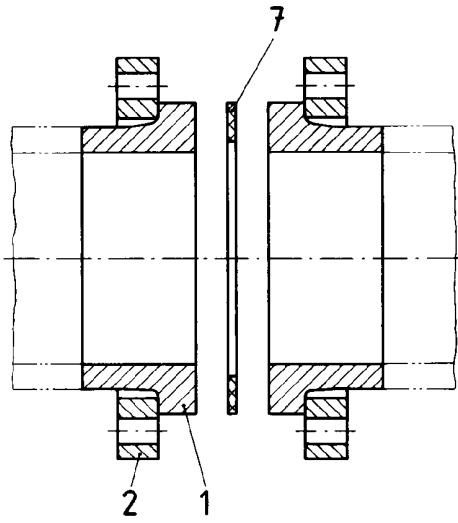

A

Item No.	Name of component
1	Short adaptor
2	Flange
7	Gasket

B

Item No.	Name of component
2	Flange
3	Long adaptor
7	Gasket

Type F2 flanged joint (for sizes from DN 15 to DN 1200)

Type F7 flanged joint (for sizes from DN 15 to DN 200)

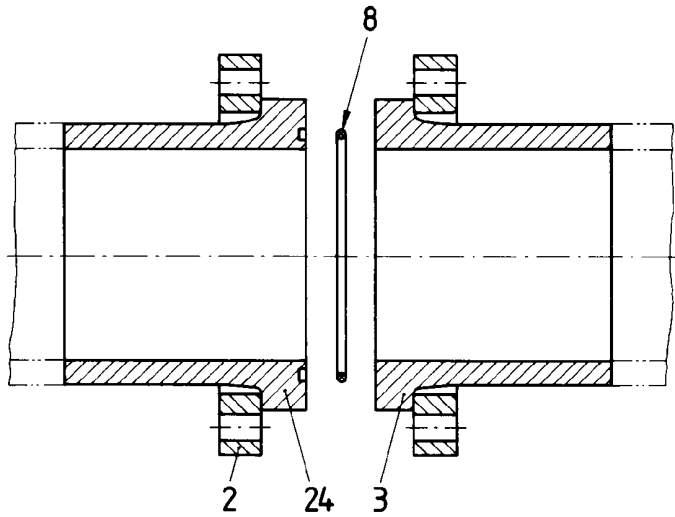
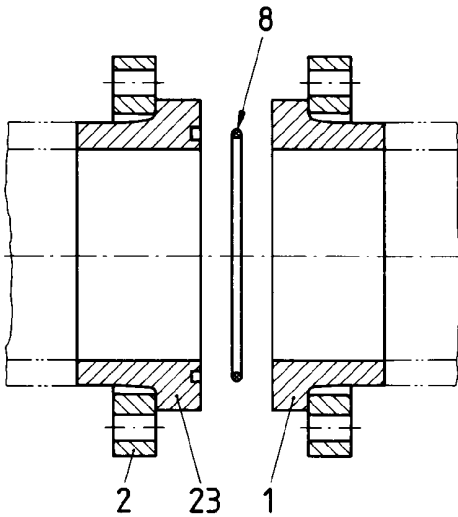

C

Item No.	Name of component
1	Short adaptor
2	Flange
8	O ring
23	Short adaptor

D

Item No.	Name of component
2	Flange
3	Long adaptor
8	O ring
24	Long adaptor

Standards referred to

DIN 1691	Flake graphite cast iron (grey cast iron); properties
DIN 2501 Part 1	Flanges; connecting dimensions
DIN 2642	Loose flanges with collar and plain collars, rated for PN 10
DIN 2673	Loose flanges and adaptors rated for PN 10
DIN 7168 Part 1	General tolerances; linear and angular dimensions
DIN 8063 Part 3	Pipe joint assemblies and fittings for unplasticized polyvinyl chloride (PVC) pressure pipes; pipe couplings; dimensions
DIN 8063 Part 4	Pipe joint assemblies and fittings for unplasticized polyvinyl chloride (PVC-U) pressure pipes; bushings, flanges and sealing elements; dimensions
DIN 8063 Part 5	(at present at the stage of draft) Pipe joint assemblies and fittings for unplasticized polyvinyl chloride (PVC-U) pressure pipes; general quality requirements and testing
DIN 8074	High-density polyethylene (PE-HD) pipes; dimensions
DIN 16901	Plastics mouldings; tolerances and acceptance conditions for linear dimensions
DIN 16 963 Part 5	(at present at the stage of draft) Pipe joint assemblies and fittings for high-density polyethylene pressure pipes; general quality requirements and testing
DIN 17 100	Steels for general structural purposes; quality standard

Explanatory notes

This standard has been prepared by Subcommittee 504.4 *Kunststoff-Fittings für Rohre aus Thermoplasten* of the *Normenausschuß Kunststoffe* (Plastics Standards Committee).

The adaptor dimensions have been specified on the assumption that the adaptors are made from a moulding compound showing the same characteristics in the long-term hydrostatic pressure test as the type 1 PE-HD pipes specified in DIN 8075 Part 1, August 1976 edition (withdrawn).

International Patent Classification

B 29 C 65/18
B 29 C 65/20
B 29 C 67/14
F 16 L 47/00